

# TECHNICAL DATASHEET



## WYE TEE 45°

03 Update - 05/2024

### TECHNICAL DATA

Article No	001 117 0045 0125
d (mm)	125
L (mm)	412
le (mm)	92
Z (mm)	277
s (mm)	11,4
Weight (Kg)	2,930
Box Quantity (pcs)	5
Box Dimension (pcs)	36x36x46,5

### IDENTIFICATION OF PRODUCT

D(mm)	125
SDR	11
RAW METARIAL	PE 100
PRESSURE CLASS	16 Bar Water 10 Bar Gas
TRADEMARK	NTG
EXECUTION	Injection Moulded
STANDARD	EN 12201-3 EN 1555-3 AS /NZS 4129

### INJECTION MOULDED

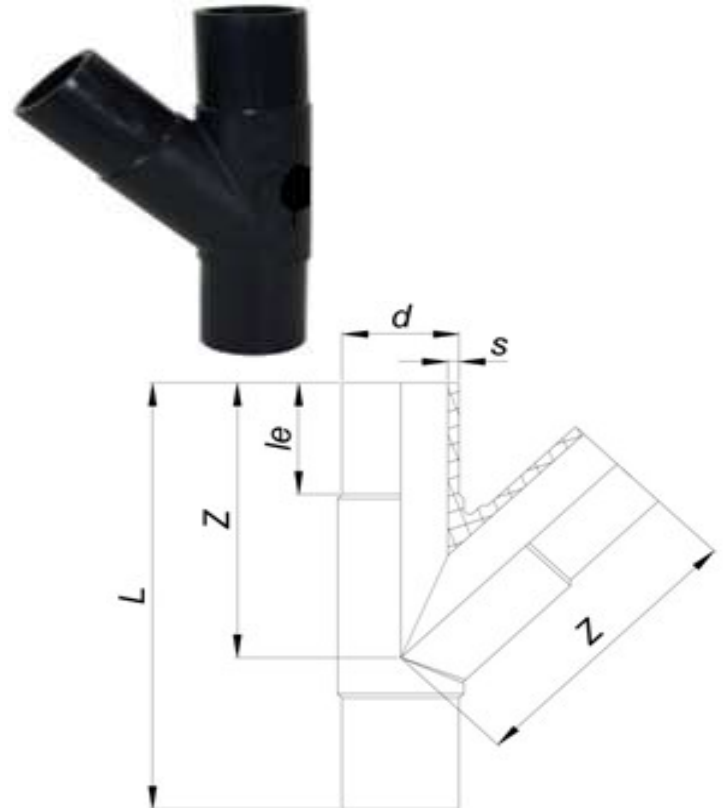

### SPECIFICATION

Long Spigot

Tolerance on diameters and thickness according to the standards. The other dimensions are specialized. Tolerance  $\pm 5\%$ . NTG PLASTIK reserves all the right to change any information without giving prior notice. The production, distribution and utilization of this document without explicit authorization is prohibited.

Fr 161 Rev 00